

# 78EZNM

Type N Male EZfit® for 7/8 in FXL-780, AVA5-50, and AVA5-50FX cable



## Product Classification

<b>Brand</b>	EZfit®
<b>Product Type</b>	Wireless and radiating connector

## General Specifications

<b>Interface</b>	N Male
<b>Body Style</b>	Straight
<b>Harmonized System (HS) Code</b>	854420 (Coaxial cable and other coaxial electric conductors)
<b>Mounting Angle</b>	Straight
<b>Ordering Note</b>	CommScope® non-standard product

## Electrical Specifications

<b>Connector Impedance</b>	50 ohm
<b>Operating Frequency Band</b>	0 – 5000 MHz
<b>Cable Impedance</b>	50 ohm
<b>3rd Order IMD, typical</b>	-116 dBm @ 1800 MHz
<b>3rd Order IMD Test Method</b>	Two +43 dBm carriers
<b>RF Operating Voltage, maximum (vrms)</b>	707.00 V
<b>dc Test Voltage</b>	2000 V
<b>Outer Contact Resistance, maximum</b>	0.30 mOhm
<b>Inner Contact Resistance, maximum</b>	2.00 mOhm
<b>Insulation Resistance, minimum</b>	5000 MOhm
<b>Peak Power, maximum</b>	10.00 kW
<b>Insertion Loss, typical</b>	0.05 dB

# 78EZNM

## Outline Drawing

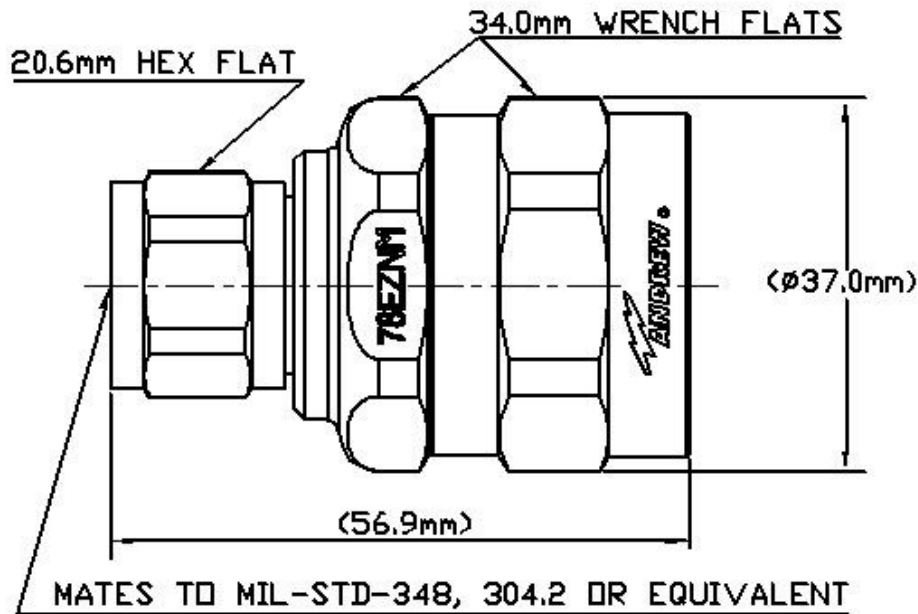

## Mechanical Specifications

<b>Outer Contact Attachment Method</b>	Clamp
<b>Inner Contact Attachment Method</b>	Captivated
<b>Outer Contact Plating</b>	Trimetal
<b>Inner Contact Plating</b>	Silver
<b>Attachment Durability</b>	25 cycles
<b>Interface Durability</b>	500 cycles
<b>Interface Durability Method</b>	IEC 61169-16:9.5
<b>Connector Retention Tensile Force</b>	1334 N   300 lbf
<b>Connector Retention Torque</b>	8.13 N-m   72.00 in lb
<b>Insertion Force</b>	66.72 N   15.00 lbf
<b>Insertion Force Method</b>	MIL-C-39012C-3.12, 4.6.9
<b>Pressurizable</b>	No
<b>Coupling Nut Proof Torque</b>	4.52 N-m   40.00 in lb
<b>Coupling Nut Retention Force</b>	444.82 N   100.00 lbf
<b>Coupling Nut Retention Force Method</b>	MIL-C-39012C-3.25, 4.6.22

## Dimensions

<b>Nominal Size</b>	7/8 in
---------------------	--------

# 78EZNM

---

<b>Diameter</b>	37.00 mm   1.46 in
<b>Length</b>	57.96 mm   2.28 in
<b>Weight</b>	152.89 g   0.34 lb

## Environmental Specifications

<b>Operating Temperature</b>	-40 °C to +85 °C (-40 °F to +185 °F)
<b>Storage Temperature</b>	-55 °C to +85 °C (-67 °F to +185 °F)
<b>Immersion Depth</b>	1 m
<b>Immersion Test Mating</b>	Mated
<b>Immersion Test Method</b>	IEC 60529:2001, IP68
<b>Water Jetting Test Mating</b>	Mated
<b>Water Jetting Test Method</b>	IEC 60529:2001, IP66
<b>Moisture Resistance Test Method</b>	MIL-STD-202F, Method 106F
<b>Mechanical Shock Test Method</b>	MIL-STD-202F, Method 213B, Test Condition C
<b>Vibration Test Method</b>	IEC 60068-2-6
<b>Corrosion Test Method</b>	MIL-STD-1344A, Method 1001.1, Test Condition A

## Standard Conditions

<b>Attenuation, Ambient Temperature</b>	20 °C   68 °F
<b>Average Power, Ambient Temperature</b>	40 °C   104 °F

## Return Loss/VSWR

<b>Frequency Band</b>	<b>VSWR</b>	<b>Return Loss (dB)</b>
50–1000 MHz	1.02	40.00
1000–1900 MHz	1.03	38.00
1900–2200 MHz	1.04	35.00
2200–2700 MHz	1.05	32.00
2700–3600 MHz	1.07	30.00
3600–5000 MHz	1.11	26.00

## Regulatory Compliance/Certifications

<b>Agency</b>	<b>Classification</b>
RoHS 2011/65/EU	Compliant by Exemption
ISO 9001:2015	Designed, manufactured and/or distributed under this quality management system
China RoHS SJ/T 11364-2014	Above Maximum Concentration Value (MCV)



## \* Footnotes

# 78EZNM

---

<b>Immersion Depth</b>	Immersion at specified depth for 24 hours
<b>Insertion Loss, typical</b>	$0.05\sqrt{\text{freq}}$ (GHz) (not applicable for elliptical waveguide)